

YAK 135 / 330/S

AIR HYDRAULIC JACKS

AIR HYDRAULIC JACKS

Air hydraulic jacks for heavy vehicles, practical and effective. The pistons move back automatically; the two descent valves guarantee perfect holding in all situations and controlled speed under load.

YAK 330/S is specific for lifting the vehicle from the chassis and for all operations where maximum stroke and capacity are required.

TECHNICAL DATA

	135	330/S
Capacity	30 t / 33 ton	80/50/25 t / 88.2/55.1/27.6 ton
Net weight	57 kg / 126 lb	103 kg / 227 lb
Working air pressure	8-10bar / 116-145psi	8-12 bar / 116-174 psi
Air consumption	400 nl / min	800 nl/min
Max stroke	230 mm / 9.06 in	525 mm / 20.7 in
Min. height	350 mm / 13.78 in	310 mm / 12.2 in
Number of pistons	1	3
Pistons stroke	230mm	165 - 170 - 190 mm / 6.5 - 6.7 - 7.5 in

DIMENSIONS

	135		330/S	
	mm / t	in / ton	mm / t	in / ton
A	1415	55.71	1430	56.3
B	1315	51.77	1320	51.97
C	725	28.54	1000	39.37
D	275	10.83	350	13.78
E	250	9.84	240	9.45
F	350	13.78	310	12.2
G	230	9.06	165	6.5
H	-	-	170	6.69
K	-	-	190	7.48
L	-	-	525	20.67
M	-	-	320	12.60
N	30	33	80	88
O	-	-	50	55
P	-	-	25	28

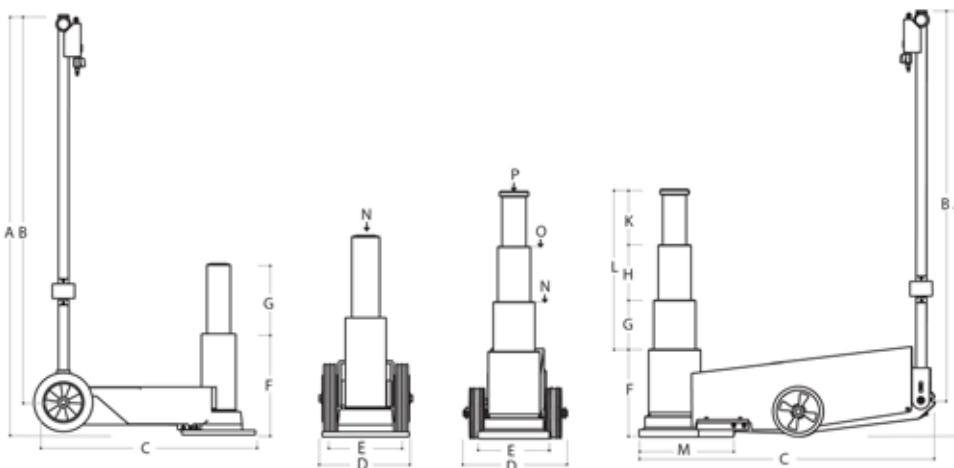



YAK 135 / 330/S

AIR HYDRAULIC JACKS



Larzep Australia Pty Ltd, 27 Metcalf Street, Dandenong South, Victoria, 3175 Australia.
Larzep Western Australia, 42 Bushland Ridge, Bibra Lake, Western Australia, 6163 Australia.
E: sales@larzep.com.au | W: www.larzep.com.au | W: www.yakjacks.com.au

